

# U.S. WALL GUIDE

## Featuring Trus Joist® TimberStrand® LSL and Parallam® PSL Wall Framing

- Engineered to meet code requirements for walls up to 30' tall
- Easy-to-use tables adaptable to a variety of wind conditions, surface finishes, and wall layouts
- Out-of-plane wind and vertical load information for designing walls that are stiff, strong, and straight
- Limited product warranty





The products in this guide are readily available through our nationwide network of distributors and dealers. For more information on other applications or other Trus Joist® products, contact your Weyerhaeuser representative.

**Code Evaluations:**  
See ICC ES ESR-1387

## TABLE OF CONTENTS

Deflection Requirements	2
Conventional Construction Applications	3
Definitions	4
Engineered Design Assumptions	4
Wind Tables	4
Design Example	5
One-Hour Wall Assembly	5
Stud Load Table and Example	6–7
Column Load Tables	8–9
Column Example	9
Header Load Table	10
Header Example	11
Multiple-Member Connections	11
Typical Tall Wall Framing	12
Wall Details	12–13
Framing Connectors	13
Allowable Holes	14
Design Properties	15



Certified Sourcing  
www.sfiprogram.org  
SFI-00008

## Choose Trus Joist® wall framing for straight, flush walls that:

- are critical for tile applications.
- allow easy countertop and cabinet installation in kitchens and bathrooms.
- give visual appeal to tall walls in great rooms and entryways.
- have the strength and stiffness to accommodate “window” walls.

Many of today’s homes have design requirements—such as walls over 10 feet tall—that exceed the code provisions for conventional construction. Trus Joist® TimberStrand® laminated strand lumber (LSL) and Parallam® parallel strand lumber (PSL) can help you meet the requirements of these challenging designs. Weyerhaeuser also offers product and design support that includes technical information, design software, and design advice from our team of skilled engineers and sales representatives.

### Tall wall software solutions

Forte® software is a single-member sizing solution created by Weyerhaeuser to help estimators, architects, and engineers design walls quickly and efficiently. Forte® software provides the most economical solutions for studs, columns, and headers, and helps you design connections for each member. Professional calculations can be printed out for engineer sign-off or to give to building officials. Ask your Weyerhaeuser representative how you can get Forte® software today.

## This guide features the following Trus Joist® wall framing products:

### 1.3E TimberStrand® LSL

**Studs:** 1½" x 3½" (2x4) • 1½" x 5½" (2x6)

**Columns:** 3½" x 5½" • 3½" x 7¼"

**Headers:** 3½" x 5½" • 3½" x 7¼" • 3½" x 8⅝"

### 1.5E TimberStrand® LSL

**Studs and Columns:** 1½" x 7¼" (2x8)

### 1.55E TimberStrand® LSL

**Studs and Columns:** 1¾" x 5½" • 1¾" x 7¼"

**Headers:** 3½" x 9½" • 3½" x 11⅞"

### 1.8E Parallam® PSL

**Columns:** 3½" x 3½" • 3½" x 5¼"  
3½" x 7" • 5¼" x 5¼"  
5¼" x 7" • 7" x 7"

**Headers:** 5¼" x 5¼"

### 2.0E Parallam® PSL

**Columns:** 3½" x 9¼" • 5¼" x 9¼"  
7" x 9¼"

**Headers:** 5¼" x 9¼"

*Other sizes may be available in Weyerhaeuser software; however, not all products are available in all markets. Contact your Weyerhaeuser representative for the sizes available in your area.*

## DEFLECTION REQUIREMENTS

### How stiff does a wall need to be?

While model building codes provide required deflection limits based on the type of finish supported by the wall framing, acceptable deflection limits are usually established by the design professional, finish-material provider, and/or building code authority. Typical deflection requirements are shown in table below.

### Code Minimum Deflection Criteria

Type of Wall	Maximum Deflection
Exterior walls with plaster or stucco finish <sup>(1)</sup>	L/360 <sup>(5)</sup>
Exterior walls with brittle finishes <sup>(1)(2)</sup>	L/240
Exterior walls with flexible finishes <sup>(1)(2)</sup>	L/120
Exterior walls with interior gypsum board finish <sup>(3)</sup>	L/180
Members supporting windows (mullions) <sup>(4)</sup>	L/175

(1) 2009, 2012 and 2015 International Residential Code (IRC), Table R301.7

(2) 2009, 2012 and 2015 International Building Code (IBC), Table 1604.3

(3) 2009, 2012 and 2015 IRC, Table R301.7, footnote d

(4) 2009 IRC, Section R612.11.2; 2012 IRC, Section R612.8.2; 2015 IRC, Section R609.8.2; 2009, 2012 and 2015 IBC, Section 2403.3

(5) For finishes that require a deflection stricter than L/360, contact your Weyerhaeuser representative.

# CONVENTIONAL CONSTRUCTION APPLICATIONS

## Limitations of Conventional Construction

For walls up to 10' in height, 2x4 and 2x6 1.3E TimberStrand® LSL studs may be conventionally specified per the limitations described on this page. Engineered design for more demanding applications is outlined on the pages that follow.

### Wind Limitations

Basic wind speed (2009):  
 < 100 mph in hurricane-prone regions;  
 < 110 mph elsewhere per IRC Section R301.2.1.1  
 Basic wind speed (2012 and 2015):  
 Figure R301.2(4)B

### Seismic Design Categories

A, B, C, D<sub>0</sub>, D<sub>1</sub>, and D<sub>2</sub>. Excludes irregular portions of structures as defined by IRC R301.2.2.2.5

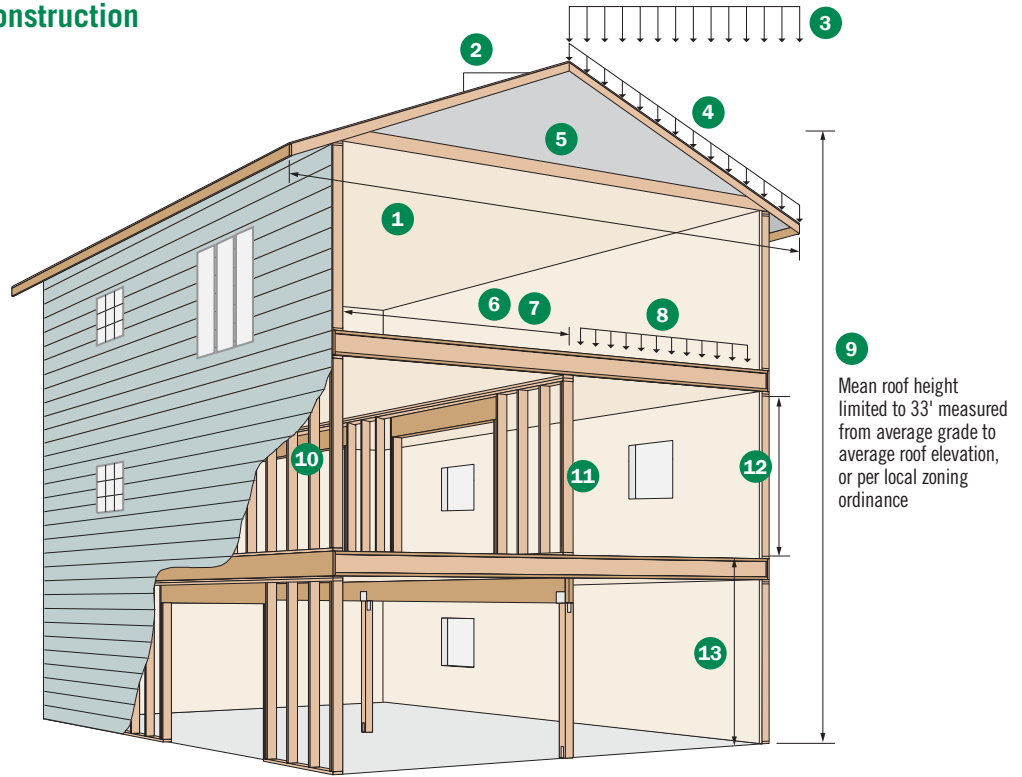

## Limitation Descriptions and IRC References

Description	2009, 2012 and 2015 IRC References
1 Maximum roof span, including overhangs, limited to 40'. Maximum tabulated rafter span (horizontal projection) and ceiling joist span of 26'.	R802.10.2.1; footnote a to IRC Tables R802.4(1), R802.4(2); footnote b to IRC Tables R802.5.1(1)-R802.5.1(8)
2 Roof pitch: 3:12 minimum, 12:12 maximum	
3 Maximum ground snow load: 70 psf	IRC Section R301.2.3
4 Maximum tabulated roof/ceiling dead load: 20 psf	IRC Tables R802.5.1(1)-R802.5.1(8)
5 Maximum tabulated rafter and ceiling joist spacing: 24" on-center	IRC Tables R802.4(1), R802.4(2), R802.5.1(1)-R802.5.1(8)
6 Maximum tabulated joist span: 26'	IRC Tables R502.3.1(1), R502.3.1(2)
7 Maximum tabulated floor joist spacing: 24" on-center	IRC Tables R502.3.1(1), R502.3.1(2)
8 Maximum uniform floor loads: 40 psf live load, 20 psf dead load	IRC Tables R502.3.1(1), R502.3.1(2)
9 Maximum of 3 stories	IRC Section R101.2
10 Maximum stud spacing: 24" on-center	IRC Table R602.3(5)
11 With TJI® joist floor systems, load-bearing walls must stack directly over bearing walls or beams below. With rectangular joists, walls may be offset a distance equal to the joist depth.	IRC Section R502.4
12 Maximum load-bearing stud length: 10' between points of lateral support	IRC Table R602.3(5)
13 Maximum story height: 10' stud height plus 16" floor framing = 11'-4"	IRC Section R301.3

## Stud Specifications for Conventional Applications per IRC Table R602.3(5)

Stud Size	Bearing Walls				Nonbearing Walls		
	Laterally unsupported stud height <sup>(1)</sup>	Maximum spacing when supporting roof and ceiling only	Maximum spacing when supporting one floor, roof, and ceiling	Maximum spacing when supporting two floors, roof, and ceiling	Maximum spacing when supporting one floor only	Laterally unsupported stud height <sup>(1)</sup>	Maximum spacing
2x4	10'	24"	16"	—	24"	14'	24"
2x6	10'	24"	24"	16"	24"	20'	24"

(1) Listed heights are distances between points of lateral support placed perpendicular to the plane of the wall.

When used in conventional construction applications, both 2x4 and 2x6 TimberStrand® LSL studs may be drilled or notched in accordance with IRC Section R602.6.

# DEFINITIONS

**Buckling Length**—Distance along the length of a member between braced points. This length is used to calculate the buckling stability of the member.

**Conventional Construction**—Generally, home design based on traditional construction methods and materials that have a history of adequate structural performance for specific building types and sizes. Both conventionally specified and pre-calculated members and connections are prescriptively specified in building codes such as the IRC and IBC, and may be combined to form a structure or structural assemblage.

**Design Wind Pressure**—The equivalent static wind pressure applied to structures to determine wind loads for buildings.

**Effective Wind Area**—The area used to determine external wind coefficients. These coefficients are used in the determination of the design wind pressures for components and cladding elements. Generally, the effective wind area is the length of a member's span times the tributary width or  $L^2/3$ , whichever is greater.

**Lateral Loads**—Loads applied to a structure in the horizontal direction. This includes loads from wind and seismic events.

**Main Force Resisting System**—Structural elements designated to provide support and stability for the overall structure. The system generally receives wind loading from more than one surface.

**Tributary Area**—A calculated area of influence surrounding a structural member. Loads within this area are added together to determine the amount of load a member is required to resist. For example, the tributary area for a wall stud is the sum of  $\frac{1}{2}$  the distance to the adjacent wall stud on each side of the stud in question. Likewise, the tributary area for a floor joist would be the sum of  $\frac{1}{2}$  the distance to the adjacent joist on each side of the joist in question.

## ENGINEERED DESIGN ASSUMPTIONS

**Design applications are limited to vertical loads, and to lateral wind loads that are perpendicular to the wall framing.** Table information is based on the strength calculations and deflection limits of wall framing members, and was generated with the following assumptions:

- Member design and lateral support requirements for bending are based on National Design Specification® (NDS®).
- Stud and column tables assume structural sheathing on one side of the wall, or a combination of gypsum wallboard and non-structural sheathing or siding applied to each side of the wall, or equivalent.
- Blocking/bracing at 8' on-center maximum. See page 12.
- Beams and columns must remain straight to within  $\frac{5L}{4608}$  (in.) of true alignment. L is the unrestrained length of the member in feet.

- If stud spacing is 19.2" or 24" on-center, trusses or rafters must be installed within 3" of the stud locations. This does not apply if studs are spaced at 16" on-center or less.
- The Components & Cladding (C&C) pressures shown in the **Wall Design Wind Pressure** table below are used only for strength calculations.
- Deflection limits are based on Main Wind Force Resisting System pressures, which were estimated by multiplying the C&C pressure by 0.70 (2009, 2012 and 2015 IRC Table R301.7 and IBC Table 1604.3).
- $\Delta = \frac{270 wL^4}{Ebd^3} + \frac{28.8 wL^2}{Ebd}$ 
  - $\Delta$  = deflection
  - w = uniform load (plf)
  - L = span (ft)
  - b = member width (in.)
  - d = member depth (in.)
  - E = modulus of elasticity (psi)

## WIND TABLES

### Wall Design Wind Pressure (PSF)<sup>(1)(2)</sup>

Exposure Category <sup>(3)</sup>	Effective Wind Area <sup>(4)</sup> (ft <sup>2</sup> )	Basic Wind Speed (mph)																
		2009 IRC/IBC or Older (ASCE 7-05: W)								2012 and 2015 IRC/IBC (ASCE 7-10: 0.6W)								
		85	90	100	110	120	130	140	150	110	115	120	130	140	150	160	170	180
B	≤ 10	14.5	16.2	20.1	24.3	28.9	33.9	39.3	45.1	14.6	15.9	17.3	20.3	23.6	27.1	30.8	34.8	39.0
	50	13.1	14.7	18.1	21.9	26.1	30.6	35.5	40.8	13.2	14.4	15.7	18.4	21.3	24.5	27.8	31.4	35.2
	≥ 100	12.5	14.0	17.3	20.9	24.9	29.2	33.9	38.9	12.5	13.7	14.9	17.5	20.3	23.3	26.6	30.0	33.6
C	≤ 10	20.1	22.6	27.9	33.7	40.1	47.1	54.6	62.7	20.3	22.1	24.1	28.3	32.8	37.7	42.9	48.4	54.3
	50	18.2	20.4	25.2	30.5	36.2	42.5	49.3	56.6	18.3	20.0	21.8	25.6	29.7	34.0	38.7	43.7	49.0
	≥ 100	17.3	19.4	24.0	29.1	34.6	40.6	47.1	54.0	17.5	19.1	20.8	24.4	28.3	32.5	37.0	41.7	46.8
D	≤ 10	23.7	26.6	32.9	39.8	47.3	55.5	64.4	73.9	23.9	26.1	28.4	33.4	38.7	44.4	50.6	57.1	64.0
	50	21.5	24.1	29.7	35.9	42.8	50.2	58.2	66.8	21.6	23.6	25.7	30.2	35.0	40.1	45.7	51.6	57.8
	≥ 100	20.5	22.9	28.3	34.3	40.8	47.9	55.5	63.7	20.6	22.5	24.5	28.8	33.4	38.3	43.6	49.2	55.2

(1) Tabulated pressures are based on the Analytical Procedure defined in ASCE 7. Values assume a Components and Cladding (C&C) member in the interior zone of an enclosed structure, with the following factors:

- Risk/occupancy category II
- Topographical factor of 1.0
- Mean roof height of 33'

(2) When designing in accordance with 2012 and 2015 IRC/IBC, the load combinations include a 0.6 factor for wind. Tabulated wind pressures in the 2012 and 2015 IRC/IBC portion of this table are reduced by 0.6 for direct use with the 2009 IRC-based load tables in this guide.

(3) Exposure categories are generally defined as follows (see ASCE 7):

- B = Urban and suburban areas, wooded areas
- C = Open terrain with scattered obstructions generally less than 30' in height
- D = Flat, unobstructed areas

(4) **Effective Wind Area** is the span times the tributary width or  $L^2/3$ , whichever is greater. For values of effective wind areas not listed, interpolation between 10 ft<sup>2</sup> and 100 ft<sup>2</sup> is allowed.

- Check local codes for any special wind pressures.

### Effective Wind Area

Wall Height	Stud/Column Effective Wind Area (ft <sup>2</sup> )
≥ 18'	100
16'	85
14'	65
12'	48
10'	33

- Values are based on  $L^2/3$  with a maximum of 100 ft<sup>2</sup>.
- The effective wind area should not be confused with the tributary area, which is used to determine the amount of load applied to an individual member.

*When designing in accordance with the 2012 or 2015 IRC/IBC, use the load tables in this guide in conjunction with the 2012 and 2015 IRC/IBC wind pressures above, which have been reduced by 0.6.*

# DESIGN EXAMPLE

## Given

- Wall height = 20'
- Rough opening = 6'
- Exposure Category "B"
- 140 mph basic wind speed
- 2015 IRC/IBC
- Flexible exterior finish with interior gypsum board finish; walls support window mullions
- Maximum column vertical load = 5,000 lbs
- Maximum header vertical load = 250 plf

When designing with C&C pressures, the effective wind area ( $L^2/3$ ) helps determine the wall design wind pressure. A smaller effective wind area results in a higher wind pressure. The effective wind area should not be confused with the tributary area, which is used to determine the amount of load applied to an individual member.

### 1. Determine effective wind areas (ft<sup>2</sup>):

- For the studs and columns, refer to the **Effective Wind Area** table on page 4. A 20' stud or column will have an effective wind area of 100 ft<sup>2</sup>.
- For each header, consult the drawing at right and use the maximum value of the rough opening (L) times the tributary width or  $L^2/3$ , whichever is greater.
  - For the top header in our example wall, use the maximum of either (6' x 5' = 30 ft<sup>2</sup>) or ( $6^2/3 = 12$  ft<sup>2</sup>).
  - For the bottom header in our example wall, use the maximum of either (6' x 10' = 60 ft<sup>2</sup>) or ( $6^2/3 = 12$  ft<sup>2</sup>).

The effective wind areas calculate to 30 ft<sup>2</sup> for the top header and 60 ft<sup>2</sup> for the bottom header, so interpolation would be required to find exact pressures. For simplicity, we will use an effective wind area of 10 ft<sup>2</sup> for each header. This allows us to skip the interpolation exercise, and provides a more conservative wind pressure.

### 2. Determine design wind pressure:

Consult the **Wall Design Wind Pressure** table on page 4, using the example wall's criteria of Exposure B, a 140 mph basic wind speed, and an effective wind area as calculated above:

- For studs/columns with an effective area of 100 ft<sup>2</sup>, the wall design lateral wind pressure is 20.3 psf.
- For headers with an effective area of 10 ft<sup>2</sup>, the wall design wind pressure is 23.6 psf.

### 3. Determine appropriate deflection criteria:

Consult the **Code Minimum Deflection Criteria** on page 2. Our example wall contains both windows (minimum L/175) and a flexible finish with interior gypsum board (minimum L/180). Because the L/180 deflection is more restrictive, the wall should be designed using the L/180 deflection values in this guide.

Refer to stud, column, and header tables on pages 6–10 to design the components for this example wall.

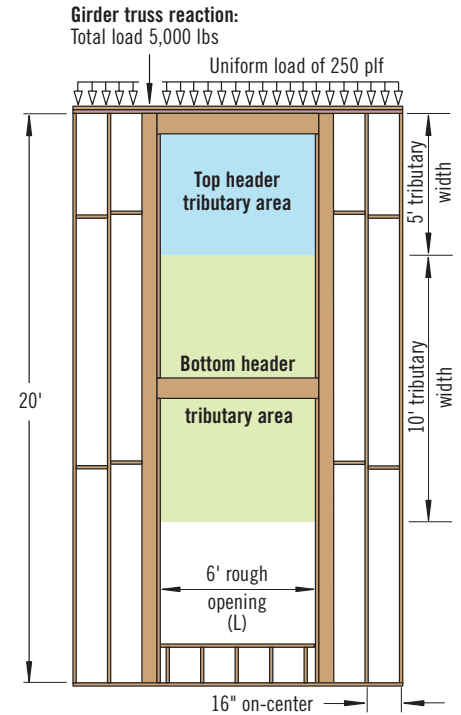

*A complete wall specification should include permanent bracing, safety bracing, blocking, connections, details, etc. See pages 11–14.*

## ONE-HOUR WALL ASSEMBLY WITH TIMBERSTRAND® LSL STUDS

**2x6 Wall Application:** 2x6 wall made with TimberStrand® LSL studs and gypsum wallboard applied horizontally. 2x6 or larger TimberStrand® LSL is permitted as a substitute in fire-rated assemblies when used in the same or larger dimensions as sawn lumber.

### TimberStrand LSL Wall Assembly

1. 2x6 TimberStrand® LSL studs, spaced 16" on-center, with double top plates and single bottom plate
  2. 5/8" Type X gypsum wallboard, 4' wide, applied horizontally. Horizontal joints are unblocked. Horizontal application of wallboard represents the direction of least fire resistance as opposed to vertical application.
  3. 2 1/4" #6 Type S drywall screws, spaced along stud at 7" on-center and covered with joint compound
  4. Wallboard joints covered with paper tape and joint compound
- The design axial compressive stress within the TimberStrand® LSL studs must not exceed **the least** of the following:
    - 435 psi
    - $F_c \times 0.30$ , where  $F_c$  is the compression design value parallel-to-grain for the TimberStrand® LSL, adjusted by all applicable adjustment factors (in accordance with the NDS®), including the column stability factor  $C_p$
    - $F_c \times 0.30$ , where  $F_c$  is calculated in accordance with the NDS®, assuming a slenderness ratio  $L_e/d$  of 21

*This assembly has been tested to ASTM E119/NFPA 251 and CAN/ULC-S101 Standards.*

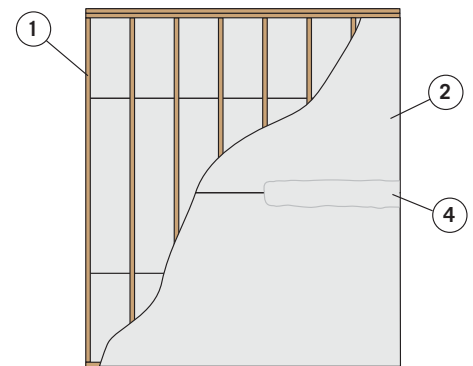

Top View (plates not shown)

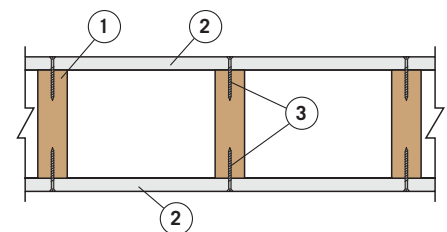

# STUD LOAD TABLE AND EXAMPLE

## Studs—Maximum Allowable Lateral (Wind) and Vertical Load

Wall Ht.	Load and Deflection	1.3E TimberStrand® LSL										1.5E TimberStrand® LSL					
		1½" x 3½"				1½" x 5½"						1½" x 7¼"					
		Lateral Load (plf)				Lateral Load (plf)						Lateral Load (plf)					
		15	20	26 <sup>(1)</sup>	30	15	20	26 <sup>(1)</sup>	30	40	50	15	20	26 <sup>(1)</sup>	30	40	50
8'	Vertical (lbs)	2,745	2,590	2,405	2,280	4,385	4,385	4,385	4,385	4,385	4,385	5,775	5,775	5,775	5,775	5,775	5,775
	Defl. Ratio	L/677	L/508	L/391	L/339	L/2,553	L/1,915	L/1,473	L/1,277	L/958	L/766	L/6,518	L/4,888	L/3,760	L/3,259	L/2,444	L/1,955
9'	Vertical (lbs)	2,175	2,010	1,820	1,690	4,385	4,385	4,385	4,385	4,385	4,385	5,775	5,775	5,775	5,775	5,775	5,775
	Defl. Ratio	L/478	L/358	L/276	L/239	L/1,812	L/1,359	L/1,045	L/906	L/679	L/543	L/4,656	L/3,492	L/2,686	L/2,328	L/1,746	L/1,397
10'	Vertical (lbs)	1,730	1,560	1,360	1,230	4,385	4,385	4,385	4,385	4,385	4,385	5,775	5,775	5,775	5,775	5,775	5,775
	Defl. Ratio	L/349	L/262	L/202	L/175	L/1,330	L/998	L/767	L/665	L/499	L/399	L/3,437	L/2,577	L/1,983	L/1,718	L/1,289	L/1,031
11'	Vertical (lbs)	1,380	1,205	1,005	870	4,385	4,385	4,385	4,385	4,230	3,775	5,775	5,775	5,775	5,775	5,775	5,775
	Defl. Ratio	L/263	L/197	L/152	L/132	L/1,005	L/754	L/580	L/502	L/377	L/301	L/2,606	L/1,955	L/1,503	L/1,303	L/977	L/782
12'	Vertical (lbs)	1,100	925			4,385	4,375	4,085	3,890	3,415	2,940	5,775	5,775	5,775	5,775	5,775	5,775
	Defl. Ratio	L/203	L/152			L/777	L/583	L/448	L/389	L/291	L/233	L/2,022	L/1,516	L/1,166	L/1,011	L/758	L/606
13'	Vertical (lbs)	870				3,980	3,725	3,420	3,220	2,725	2,230	5,775	5,775	5,775	5,775	5,775	5,775
	Defl. Ratio	L/160				L/613	L/460	L/354	L/307	L/230	L/184	L/1,599	L/1,199	L/922	L/799	L/600	L/480
14'	Vertical (lbs)	690				3,435	3,165	2,855	2,650	2,135	1,620	5,775	5,775	5,775	5,775	5,775	5,775
	Defl. Ratio	L/128				L/492	L/369	L/284	L/246	L/185	L/148	L/1,286	L/964	L/742	L/643	L/482	L/386
15'	Vertical (lbs)					2,965	2,690	2,370	2,160	1,635	1,095	5,775	5,775	5,775	5,775	5,775	5,775
	Defl. Ratio					L/401	L/301	L/231	L/201	L/150	L/120	L/1,049	L/787	L/605	L/525	L/393	L/315
16'	Vertical (lbs)					2,560	2,285	1,960	1,745	1,205		5,775	5,775	5,775	5,775	5,775	5,245
	Defl. Ratio					L/331	L/248	L/191	L/166	L/124		L/867	L/650	L/500	L/434	L/325	L/260
17'	Vertical (lbs)					2,210	1,930	1,605	1,385			5,775	5,775	5,775	5,625	5,020	4,425
	Defl. Ratio					L/276	L/207	L/159	L/138			L/725	L/543	L/418	L/362	L/272	L/217
18'	Vertical (lbs)					1,910	1,630	1,295				5,775	5,565	5,180	4,930	4,315	3,705
	Defl. Ratio					L/233	L/175	L/135				L/612	L/459	L/353	L/306	L/229	L/184
19'	Vertical (lbs)					1,650	1,365					5,295	4,960	4,570	4,315	3,690	3,070
	Defl. Ratio					L/198	L/149					L/521	L/391	L/301	L/261	L/195	L/156
20'	Vertical (lbs)					1,420	1,135					4,765	4,425	4,030	3,775	3,140	2,505
	Defl. Ratio					L/170	L/128					L/447	L/336	L/258	L/224	L/168	L/134
21'	Vertical (lbs)					1,220						4,295	3,950	3,550	3,290	2,650	
	Defl. Ratio					L/147						L/387	L/290	L/223	L/193	L/145	
22'	Vertical (lbs)					1,040						3,875	3,525	3,125	2,860	2,210	
	Defl. Ratio					L/128						L/337	L/253	L/194	L/168	L/126	
23'	Vertical (lbs)											3,495	3,150	2,745	2,480		
	Defl. Ratio											L/295	L/221	L/170	L/148		
24'	Vertical (lbs)											3,160	2,810	2,400	2,135		
	Defl. Ratio											L/260	L/195	L/150	L/130		
25'	Vertical (lbs)											2,855	2,505	2,095			
	Defl. Ratio											L/230	L/173	L/133			
26'	Vertical (lbs)											2,580	2,230				
	Defl. Ratio											L/205	L/154				
27'	Vertical (lbs)											2,330	1,980				
	Defl. Ratio											L/183	L/137				
28'	Vertical (lbs)											2,105	1,755				
	Defl. Ratio											L/164	L/123				
29'	Vertical (lbs)											1,900					
	Defl. Ratio											L/148					
30'	Vertical (lbs)											1,715					
	Defl. Ratio											L/134					

(1) Load based on a wind pressure of 19.1 psf and studs spaced at 16" on-center.

### General Notes

- Table is based on:
  - A load duration factor of 1.60.
  - Full-width blocking at a maximum vertical spacing of 8' on-center.
  - A buckling length coefficient of  $K_e = 0.85$ . For deflection, use  $K_e = 1.0$ .
  - Axial loads applied eccentrically, at a distance of  $\frac{1}{3}$  of the wall thickness dimension of the stud, measured from the stud centerline.
  - A compression perpendicular-to-grain stress of 425 psi, adjusted per NDS®, 3.10.4.
  - A code-allowed repetitive-member increase of 4%.

### Stud Example

For the **Design Example** on page 5, design 20' studs for lateral wind pressure of 20.3 psf and a maximum vertical load of 250 plf.

- Determine the maximum stud length:**  
The maximum stud length in this example wall is 20'.
- Calculate the lateral load in plf:**  
This example uses 16" on-center studs, so calculate the lateral load in plf and the vertical load in lbs as follows:  
 $20.3 \text{ psf} \times 16/12 = 27.1 \text{ plf}$ ;  $250 \text{ plf} \times 16/12 = 333 \text{ lbs}$ .
- Select the appropriate studs:**  
In the **Stud Load Table**, scan across the 20' row until you find a cell in the

*Stud Example continued on page 7*

# STUD LOAD TABLE AND EXAMPLE

## Studs—Maximum Allowable Lateral (Wind) and Vertical Load *continued*

Wall Ht.	Load and Deflection	1.55E TimberStrand® LSL											
		1¾" x 5½"						1¾" x 7¼"					
		Lateral Load (plf)						Lateral Load (plf)					
	15	20	26 <sup>(1)</sup>	30	40	50	15	20	26 <sup>(1)</sup>	30	40	50	
8'	Vertical (lbs)	4,965	4,965	4,965	4,965	4,965	4,965	6,550	6,550	6,550	6,550	6,550	6,550
	Defl. Ratio	L/3,552	L/2,664	L/2,049	L/1,776	L/1,332	L/1,066	L/7,857	L/5,893	L/4,533	L/3,929	L/2,946	L/2,357
9'	Vertical (lbs)	4,965	4,965	4,965	4,965	4,965	4,965	6,550	6,550	6,550	6,550	6,550	6,550
	Defl. Ratio	L/2,520	L/1,890	L/1,454	L/1,260	L/945	L/756	L/5,613	L/4,210	L/3,238	L/2,807	L/2,105	L/1,684
10'	Vertical (lbs)	4,965	4,965	4,965	4,965	4,965	4,965	6,550	6,550	6,550	6,550	6,550	6,550
	Defl. Ratio	L/1,851	L/1,388	L/1,068	L/925	L/694	L/555	L/4,143	L/3,107	L/2,390	L/2,072	L/1,554	L/1,243
11'	Vertical (lbs)	4,965	4,965	4,965	4,965	4,965	4,965	6,550	6,550	6,550	6,550	6,550	6,550
	Defl. Ratio	L/1,398	L/1,048	L/806	L/699	L/524	L/419	L/3,142	L/2,356	L/1,813	L/1,571	L/1,178	L/943
12'	Vertical (lbs)	4,965	4,965	4,965	4,965	4,965	4,965	6,550	6,550	6,550	6,550	6,550	6,550
	Defl. Ratio	L/1,081	L/811	L/624	L/541	L/405	L/324	L/2,437	L/1,828	L/1,406	L/1,219	L/914	L/731
13'	Vertical (lbs)	4,965	4,965	4,965	4,965	4,950	4,500	6,550	6,550	6,550	6,550	6,550	6,550
	Defl. Ratio	L/853	L/640	L/492	L/427	L/320	L/256	L/1,928	L/1,446	L/1,112	L/964	L/723	L/578
14'	Vertical (lbs)	4,965	4,965	4,795	4,600	4,130	3,670	6,550	6,550	6,550	6,550	6,550	6,550
	Defl. Ratio	L/685	L/514	L/395	L/342	L/257	L/205	L/1,550	L/1,163	L/894	L/775	L/581	L/465
15'	Vertical (lbs)	4,670	4,410	4,110	3,915	3,435	2,965	6,550	6,550	6,550	6,550	6,550	6,550
	Defl. Ratio	L/558	L/418	L/322	L/279	L/209	L/167	L/1,265	L/949	L/730	L/632	L/474	L/379
16'	Vertical (lbs)	4,095	3,830	3,530	3,330	2,845	2,365	6,550	6,550	6,550	6,550	6,550	6,550
	Defl. Ratio	L/461	L/345	L/266	L/230	L/173	L/138	L/1,045	L/784	L/603	L/523	L/392	L/314
17'	Vertical (lbs)	3,600	3,335	3,025	2,825	2,335		6,550	6,550	6,550	6,550	6,550	5,950
	Defl. Ratio	L/385	L/288	L/222	L/192	L/144		L/874	L/655	L/504	L/437	L/328	L/262
18'	Vertical (lbs)	3,170	2,905	2,595	2,395	1,900		6,550	6,550	6,550	6,335	5,710	5,095
	Defl. Ratio	L/324	L/243	L/187	L/162	L/122		L/737	L/553	L/425	L/369	L/277	L/221
19'	Vertical (lbs)	2,800	2,530	2,220	2,020			6,550	6,260	5,860	5,600	4,965	4,340
	Defl. Ratio	L/276	L/207	L/159	L/138			L/628	L/471	L/362	L/314	L/236	L/188
20'	Vertical (lbs)	2,470	2,205	1,895				5,965	5,620	5,215	4,950	4,305	3,675
	Defl. Ratio	L/237	L/178	L/137				L/539	L/405	L/311	L/270	L/202	L/162
21'	Vertical (lbs)	2,185	1,920					5,400	5,045	4,640	4,375	3,725	3,080
	Defl. Ratio	L/205	L/154					L/467	L/350	L/269	L/233	L/175	L/140
22'	Vertical (lbs)	1,935	1,670					4,895	4,540	4,125	3,860	3,205	2,550
	Defl. Ratio	L/178	L/134					L/406	L/305	L/234	L/203	L/152	L/122
23'	Vertical (lbs)	1,715						4,440	4,080	3,670	3,400	2,740	
	Defl. Ratio	L/156						L/356	L/267	L/205	L/178	L/133	
24'	Vertical (lbs)	1,515						4,035	3,675	3,260	2,990		
	Defl. Ratio	L/137						L/313	L/235	L/181	L/157		
25'	Vertical (lbs)	1,340						3,665	3,305	2,890	2,620		
	Defl. Ratio	L/122						L/278	L/208	L/160	L/139		
26'	Vertical (lbs)							3,335	2,975	2,560	2,285		
	Defl. Ratio							L/247	L/185	L/142	L/123		
27'	Vertical (lbs)							3,035	2,675	2,260			
	Defl. Ratio							L/221	L/165	L/127			
28'	Vertical (lbs)							2,765	2,405				
	Defl. Ratio							L/198	L/148				
29'	Vertical (lbs)							2,520	2,160				
	Defl. Ratio							L/178	L/134				
30'	Vertical (lbs)							2,295	1,935				
	Defl. Ratio							L/161	L/121				

(1) Load based on a wind pressure of 19.1 psf and studs spaced at 16" on-center.

### Stud Example *continued* from page 6

30 plf Lateral Load column that meets the L/180 deflection and the 333 lbs vertical load criteria. According to the table, a 1.3E TimberStrand® LSL 2x6 stud is not an option. If the stud spacing is changed to 12" on-center (for a plf of 20.3), it still would not meet the L/180 requirement. However, a 1.5E TimberStrand® LSL 2x8 stud (at 3,775 lbs and L/224) spaced at 16" on-center meets the requirements, making it the best option for this wall.

#### ■ Design stud connections:

Convert 27.1 plf into a reaction (uniform load x length/2):  $27.1 (20'/2) = 271$  lbs. Use the Lateral Connections tables on page 13 to select a nail or angle clip connection that meets or exceeds 271 lbs. For this example a nailed connection can be calculated as  $271/104 = 2.61$ , so three 16d (0.131" x 3¼") nails (nailed through the plate into the end grain) would work. For an angle clip connection, one Simpson Strong-Tie® A34 angle clip at the top and bottom plate is sufficient.

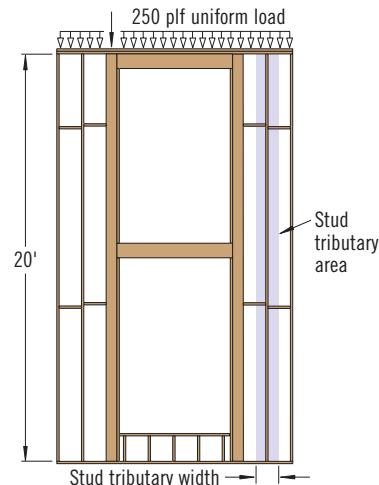

# COLUMN LOAD TABLES

## Columns—Maximum Allowable Lateral (Wind) Load (PLF)/Vertical Load (lbs)

Defl. Ratio	Wall Ht.	Max. Defl.	3½" Wall Thickness						5½" Wall Thickness							
			TimberStrand® LSL			Parallam® PSL			TimberStrand® LSL			Parallam® PSL				
			1.3E			1.8E			1.3E		1.55E	1.8E			2.0E	
			Double 2x4 <sup>(1)</sup>	5½" x 3½" (Plank)	7¼" x 3½" (Plank)	3½" x 3½"	5¼" x 3½" (Plank)	7" x 3½" (Plank)	Dbl 2x6 <sup>(1)</sup>	3½" x 5½"	Double 1¾" x 5½" <sup>(1)</sup>	3½" x 5½"	5¼" x 5¼"	7" x 5¼" (Plank)	9¼" x 5¼" (Plank)	
L/360	30'	1.00"														
	28'	0.93"														
	26'	0.87"														
	24'	0.80"														
	22'	0.73"												23/8,165	33/11,675	
	20'	0.67"										22/7,070	30/9,385	44/13,235		
	18'	0.60"										29/8,235	39/10,955	58/15,165		
	16'	0.53"										27/6,375	40/9,655	54/12,830	80/17,295	
	14'	0.47"							23/5,510	27/3,620	32/5,985	38/6,410	38/7,580	58/11,400	77/15,220	113/18,765
	12'	0.40"			25/5,075		25/5,160	34/6,850	41/3,640	47/6,890	57/6,630	57/7,810	86/11,715	115/15,620	169/19,800	
L/240	12'	0.40"		31/4,840	40/6,415	27/4,350	40/6,540	54/8,695	64/3,625	75/7,300	90/6,720	91/7,810	136/11,715	182/15,620	267/20,590	
	10'	0.33"	29/2,345	53/6,300	70/8,300	47/5,205	70/7,810	94/10,415	110/3,515	129/7,450	154/6,655	156/7,810	234/11,715	300/15,620	300/20,640	
	8'	0.27"	56/2,360	103/8,180	136/10,785	91/5,205	136/7,810	182/10,415	212/3,285	248/7,215	295/6,390	300/7,810	300/11,715	300/15,620	300/20,640	
	30'	1.50"														
	28'	1.40"														
	26'	1.30"														
	24'	1.20"												26/5,535	34/7,425	50/10,570
	22'	1.10"												33/6,360	45/8,420	66/11,890
	20'	1.00"								21/2,970	24/3,855	29/4,870	29/4,855	44/7,315	59/9,730	87/13,510
	L/180	18'	0.90"								29/3,065	34/4,370	40/5,355	40/5,610	61/8,440	81/11,270
16'		0.80"			25/3,720		26/3,750	34/5,030	41/3,125	48/5,060	57/5,615	58/6,480	87/9,825	116/13,100	170/16,975	
14'		0.70"		29/3,430	38/4,530	25/3,100	38/4,630	51/6,160	61/3,105	71/5,660	85/5,750	86/7,545	129/11,525	173/15,315	254/18,370	
12'		0.60"	25/1,985	46/4,265	61/5,605	40/3,860	61/5,755	81/7,685	97/2,985	113/5,775	135/5,705	136/7,810	205/11,715	273/15,620	300/20,590	
10'		0.50"	43/2,055	80/5,355	105/7,075	70/4,870	105/7,310	141/9,710	166/2,750	194/5,545	231/5,460	234/7,805	300/11,715	300/15,620	300/20,640	
8'		0.40"	84/2,005	155/6,760	204/8,920	136/5,205	205/7,810	273/10,410	300/2,465	300/6,215	300/6,340	300/7,810	300/11,715	300/15,620	300/20,640	
30'		2.00"														
28'		1.87"														
26'		1.73"														
24'		1.60"										22/3,385	23/3,305	34/5,035	46/6,670	67/9,535
22'	1.47"															
20'	1.33"								21/2,485	24/2,985	29/3,805	30/3,725	45/5,640	60/7,515	88/10,620	
L/180	18'	1.20"								28/2,585	33/3,295	39/4,305	39/4,270	59/6,445	79/8,575	117/11,885
	16'	1.07"		26/2,530	34/3,345	23/2,270	34/3,425	46/4,545	55/2,620	64/4,155	76/4,840	77/5,470	116/8,300	155/11,050	227/14,435	
	14'	0.93"	21/1,630	39/3,035	51/4,015	34/2,755	51/4,130	68/5,510	82/2,515	95/4,435	114/4,825	115/6,095	173/9,335	230/12,485	300/16,640	
	12'	0.80"	33/1,745	62/3,675	81/4,870	54/3,360	81/5,040	109/6,690	129/2,300	151/4,200	180/4,630	182/6,035	273/10,210	300/15,620	300/20,590	
	10'	0.67"	58/1,740	106/4,470	140/5,880	94/4,080	141/6,125	188/8,165	221/1,835	258/3,455	300/4,260	300/5,750	300/11,715	300/15,620	300/20,640	
	8'	0.53"	112/1,620	206/5,170	272/6,800	182/4,375	273/7,250	282/10,415	300/2,465	300/6,215	300/6,340	300/7,810	300/11,715	300/15,620	300/20,640	

(1) For 3-ply and 4-ply built-up columns, multiply table values by 1.5 and 2.0, respectively. See page 11 for connection requirements.

▪ Green numbers refer to lateral (wind) load (PLF). Black numbers refer to vertical load (lbs).

### General Notes

- Tables are based on:
  - A load duration factor of 1.60.
  - Full-width blocking at a maximum vertical spacing of 8' on-center.
  - A buckling length coefficient of  $K_e = 0.85$ . For deflection use  $K_e = 1.0$ .
  - Axial loads applied eccentrically, at a distance of ½ of the wall thickness dimension of the column, measured from the column centerline.
  - A compression perpendicular-to-grain stress of 425 psi.
- Solid sections required where specified. Built-up columns require reductions. Contact your Weyerhaeuser representative for assistance.

### Beam Orientation

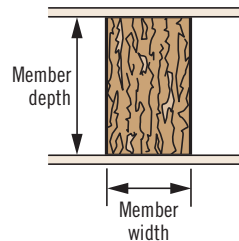

### Plank Orientation

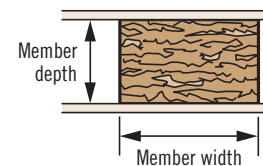

Some columns are listed in both beam and plank orientation. The first dimension is for member width, and the second dimension is for member depth (wall thickness).

TimberStrand® LSL and untreated Parallam® PSL are intended for dry-use applications

Not all products are available in all markets. Contact your Weyerhaeuser representative for information.



# COLUMN LOAD TABLES AND EXAMPLE

## Columns—Maximum Allowable Lateral (Wind) Load (PLF)/Vertical Load (lbs)

Defl. Ratio	Wall Ht.	Max. Defl.	7¼" Wall Thickness						9¼" Wall Thickness		
			TimberStrand® LSL			Parallam® PSL			Parallam® PSL		
			1.5E	1.3E	1.55E	1.8E		2.0E	2.0E		
			Dbl 2x8 <sup>(1)</sup>	3½" x 7¼"	Double 1¾" x 7¼" <sup>(1)</sup>	3½" x 7"	5¼" x 7"	7" x 7"	9¼" x 7" (Plank)	3½" x 9¼"	5¼" x 9¼"
L/360	30'	1.00"					21/8,945	28/11,960	41/16,925	35/12,095	53/18,180
	28'	0.93"					25/10,045	34/13,370	50/18,725	43/12,560	65/18,875
	26'	0.87"			20/7,255	21/7,445	32/11,195	43/14,945	63/20,655	54/12,965	82/19,485
	24'	0.80"	21/5,505	21/6,555	26/7,800	27/8,365	40/12,675	54/16,905	80/22,795	69/13,240	104/20,010
	22'	0.73"	28/5,595	28/7,345	33/8,220	35/9,485	53/14,295	70/19,185	103/24,515	90/13,385	135/20,460
	20'	0.67"	37/5,685	37/8,360	44/8,505	47/10,415	70/15,620	94/20,825	138/25,645	119/13,505	179/20,640
	18'	0.60"	50/5,730	51/9,005	61/8,665	64/10,415	96/15,620	128/20,825	188/26,585	162/13,605	244/20,640
	16'	0.53"	72/5,685	73/9,370	87/8,730	91/10,415	136/15,620	182/20,825	267/27,350	230/13,685	282/20,640
	14'	0.47"	107/5,595	108/9,580	129/8,690	135/10,415	202/15,620	270/20,825	300/27,520	300/13,750	300/20,640
	12'	0.40"	168/5,430	170/9,510	203/8,500	212/10,415	300/15,620	300/20,825	300/27,520	300/13,760	300/20,640
	10'	0.33"	286/5,140	289/9,080	300/8,640	300/10,415	300/15,620	300/20,825	300/27,520	300/13,760	300/20,640
	8'	0.27"	300/6,010	300/10,785	300/9,965	300/10,415	300/15,620	300/20,825	300/27,520	300/13,760	300/20,640
L/240	30'	1.50"			20/5,195	21/5,300	31/8,050	42/10,720	61/15,230	53/10,640	80/16,210
	28'	1.40"	20/4,560	20/4,600	24/5,805	25/5,930	38/8,920	51/11,920	75/16,705	65/11,280	98/17,215
	26'	1.30"	25/4,740	25/5,090	30/6,460	32/6,525	48/9,870	64/13,220	94/18,290	82/11,775	123/18,040
	24'	1.20"	32/4,865	32/5,635	39/6,860	40/7,325	61/11,005	81/14,775	120/19,960	104/12,100	156/18,750
	22'	1.10"	42/4,925	42/6,230	50/7,175	53/8,105	79/12,325	106/16,475	155/21,690	135/12,105	202/19,225
	20'	1.00"	55/4,990	56/6,910	67/7,340	70/9,100	105/13,815	141/18,465	207/23,155	179/11,960	226/20,640
	18'	0.90"	76/4,940	77/7,265	92/7,405	96/9,890	144/15,455	192/20,760	251/25,880	244/11,620	251/20,640
	16'	0.80"	108/4,830	109/7,370	130/7,370	136/10,165	205/15,620	273/20,825	282/27,350	282/12,865	282/20,640
	14'	0.70"	160/4,630	162/7,190	193/7,145	202/10,095	300/15,620	300/20,825	300/27,520	300/13,750	300/20,640
	12'	0.60"	252/4,285	255/6,600	300/6,755	300/10,155	300/15,620	300/20,825	300/27,520	300/13,760	300/20,640
	10'	0.50"	300/5,015	300/8,820	300/8,640	300/10,415	300/15,620	300/20,825	300/27,520	300/13,760	300/20,640
	8'	0.40"	300/6,010	300/10,785	300/9,965	300/10,415	300/15,620	300/20,825	300/27,520	300/13,760	300/20,640
L/180	30'	2.00"	22/3,825	22/3,655	26/4,710	28/4,710	42/7,130	56/9,560	82/13,555	71/9,110	107/13,975
	28'	1.87"	27/4,035	27/3,995	32/5,175	34/5,190	51/7,865	68/10,545	101/14,720	87/9,535	131/14,670
	26'	1.73"	34/4,145	34/4,340	41/5,625	43/5,650	64/8,615	86/11,505	126/15,970	109/9,810	164/15,150
	24'	1.60"	43/4,240	43/4,745	52/5,965	54/6,245	81/9,490	109/12,665	160/17,230	139/9,835	188/16,730
	22'	1.47"	56/4,260	56/5,140	67/6,155	70/6,845	106/10,345	141/13,930	205/18,540	180/9,600	205/19,060
	20'	1.33"	74/4,245	75/5,485	89/6,230	94/7,390	141/11,280	188/15,180	226/22,080	226/9,755	226/20,640
	18'	1.20"	101/4,140	103/5,515	122/6,160	128/7,780	192/12,215	251/16,810	251/25,880	251/11,355	251/20,640
	16'	1.07"	144/3,900	146/5,240	174/5,895	182/7,575	273/12,785	282/20,825	282/27,350	282/12,865	282/20,640
	14'	0.93"	214/3,520	216/4,575	258/5,405	270/6,905	300/15,620	300/20,825	300/27,520	300/13,750	300/20,640
	12'	0.80"	300/3,530	300/4,855	300/6,755	300/10,155	300/15,620	300/20,825	300/27,520	300/13,760	300/20,640
	10'	0.67"	300/5,015	300/8,820	300/8,640	300/10,410	300/15,620	300/20,825	300/27,520	300/13,760	300/20,640
	8'	0.53"	300/6,010	300/10,785	300/9,965	300/10,410	300/15,620	300/20,825	300/27,520	300/13,760	300/20,640

(1) For 3-ply and 4-ply built-up columns, multiply table values by 1.5 and 2.0, respectively. See page 11 for connection requirements.

■ Green numbers refer to lateral (wind) load (PLF). Black numbers refer to vertical load (lbs).

### Column Example

For the **Design Example** wall on page 5, design 20' columns for lateral wind pressure of 20.3 psf and vertical loading of 5,000 lbs:

**Note:** Vertical load is the load applied to the top of the column, excluding the header reaction. The header reaction is assumed to transfer directly to the trimmers.

■ **Calculate the lateral load in plf:**

The calculated wind pressure in the example is 20.3 psf, so 20.3 x 3.67' tributary width = 74.5 plf.

■ **Select an appropriate column:**

Scan the L/180 section of the **Column Load Tables** to find a 20' column that meets or exceeds the 74.5 plf lateral load and the 5,000 lbs vertical load. For this example, a 7" x 5¼" 1.8E Parallam® PSL column (at 79/8,575), used in plank orientation, will work for a 2x6 wall. Alternatively, a double 1¾" x 7¼" 1.55E TimberStrand® LSL column (at 89/6,230) would work for a 2x8 wall.

■ **Design the column to wall plate connections:**

Convert 74.5 plf into a reaction (uniform load x length/2): 74.5 (20'/2) = 745 lbs. Use the **Lateral Connections** tables on page 13 to select a connection that meets or exceeds 745 lbs. For this example 745/515 = 1.45; so according to the **Angle Clips** table, two Simpson Strong-Tie® A34 connectors would be required—one on each side of the column, at both the top and bottom plates.

Girder truss reaction:

Total load 5,000 lbs

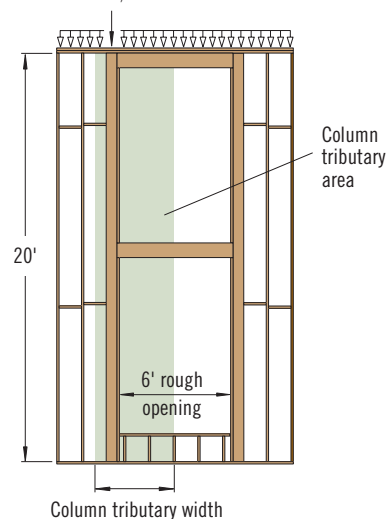

# HEADER LOAD TABLE

## Headers—Maximum Allowable Lateral (Wind) Load (PLF)/Vertical Load (PLF)

Lateral Def. Ratio	Rough Opening	Max. Def.	3½" Wall Thickness					5½" Wall Thickness			7¼" Wall Thickness
			TimberStrand® LSL					TimberStrand® LSL	Parallam® PSL		TimberStrand® LSL
			1.3E			1.55E		1.3E	1.8E	2.0E	1.3E
			3½" x 5½"	3½" x 7¼"	3½" x 8⅝"	3½" x 9½"	3½" x 11⅞"	5½" x 3½" (Plank)	5¼" x 5¼"	5¼" x 9¼"	7¼" x 3½" (Plank)
L/360	12'	0.41"	30/30	40/80	45/135	60/215	75/335		130/60	250/385	
	10'	0.34"	50/70	65/165	80/275	<b>100/435</b>	<b>130/535</b>	120/25	220/130	<b>425/785</b>	270/35
	9'	0.31"	65/110	90/250	105/415	<b>140/575</b>	<b>175/695</b>	165/40	295/200	<b>490/1,170</b>	365/55
	8'	0.28"	95/175	125/395	<b>150/645</b>	<b>195/765</b>	<b>245/925</b>	225/70	410/320	<b>500/1,605</b>	500/90
	7'	0.24"	140/295	<b>180/650</b>	<b>215/940</b>	<b>285/1,040</b>	<b>310/1,220</b>	330/120	500/535	<b>500/1,830</b>	500/160
	6'	0.21"	215/525	<b>280/895</b>	<b>335/1,230</b>	<b>360/1,420</b>	<b>360/1,415</b>	500/220	500/955	<b>500/2,125</b>	500/290
	5'	0.18"	355/690	<b>430/1,230</b>	<b>430/1,690</b>	<b>430/1,690</b>	<b>430/1,685</b>	500/370	<b>500/1,525</b>	<b>500/2,535</b>	500/485
	4'	0.14"	<b>500/1,125</b>	<b>500/1,995</b>	<b>500/2,090</b>	<b>500/2,090</b>	<b>500/2,085</b>	500/685	<b>500/2,060</b>	<b>500/3,135</b>	500/900
3'	0.11"	<b>500/2,020</b>	<b>500/2,740</b>	<b>500/2,735</b>	<b>500/2,735</b>	<b>500/2,735</b>	500/1,340	<b>500/2,930</b>	<b>500/4,105</b>	500/1,770	
L/240	12'	0.61"	45/30	60/80	70/135	90/215	115/295		195/60	370/385	
	10'	0.51"	75/70	100/165	115/275	155/380	<b>190/460</b>	180/25	325/130	<b>440/785</b>	405/35
	9'	0.46"	100/110	135/250	160/415	<b>210/485</b>	<b>245/605</b>	245/40	440/200	<b>490/1,170</b>	490/55
	8'	0.41"	140/175	185/395	<b>220/620</b>	<b>275/655</b>	<b>275/885</b>	340/70	500/320	<b>500/1,605</b>	500/90
	7'	0.36"	210/295	275/540	<b>310/770</b>	<b>310/1,000</b>	<b>310/1,220</b>	495/95	500/535	<b>500/1,830</b>	500/160
	6'	0.31"	320/380	<b>360/750</b>	<b>360/1,175</b>	<b>360/1,420</b>	<b>360/1,415</b>	500/220	500/955	<b>500/2,125</b>	500/290
	5'	0.26"	430/580	<b>430/1,230</b>	<b>430/1,690</b>	<b>430/1,690</b>	<b>430/1,685</b>	500/370	500/1,525	<b>500/2,535</b>	500/485
	4'	0.21"	<b>500/1,125</b>	<b>500/1,995</b>	<b>500/2,090</b>	<b>500/2,090</b>	<b>500/2,085</b>	500/685	500/2,060	<b>500/3,135</b>	500/900
3'	0.16"	<b>500/2,020</b>	<b>500/2,740</b>	<b>500/2,735</b>	<b>500/2,735</b>	<b>500/2,735</b>	500/1,340	500/2,930	<b>500/4,105</b>	500/1,770	
L/180	12'	0.82"	60/30	75/80	90/135	120/210	150/255		255/60	370/385	
	10'	0.68"	100/70	130/165	155/275	205/325	220/430	240/25	435/130	<b>440/785</b>	440/35
	9'	0.62"	135/110	175/250	210/415	245/440	<b>245/605</b>	325/40	490/200	<b>490/1,170</b>	490/55
	8'	0.55"	190/175	250/340	275/510	<b>275/655</b>	<b>275/885</b>	455/25	500/320	<b>500/1,605</b>	500/90
	7'	0.48"	275/225	310/470	<b>310/770</b>	<b>310/1,000</b>	<b>310/1,220</b>	500/90	500/535	<b>500/1,830</b>	500/160
	6'	0.42"	360/320	<b>360/750</b>	<b>360/1,175</b>	<b>360/1,420</b>	<b>360/1,415</b>	500/220	500/955	<b>500/2,125</b>	500/290
	5'	0.35"	430/580	<b>430/1,230</b>	<b>430/1,690</b>	<b>430/1,690</b>	<b>430/1,685</b>	500/370	<b>500/1,525</b>	<b>500/2,535</b>	500/485
	4'	0.28"	<b>500/1,125</b>	<b>500/1,995</b>	<b>500/2,090</b>	<b>500/2,090</b>	<b>500/2,085</b>	500/685	<b>500/2,060</b>	<b>500/3,135</b>	500/900
3'	0.22"	<b>500/2,020</b>	<b>500/2,740</b>	<b>500/2,735</b>	<b>500/2,735</b>	<b>500/2,735</b>	500/1,340	<b>500/2,930</b>	<b>500/4,105</b>	500/1,770	

- **Bold italic** values require two trimmers (3" bearing) at ends. Single trimmers may work for lightly loaded **bold italic** sections; see table below.
- **Green numbers** refer to lateral (wind) load (PLF). Black numbers refer to vertical load (PLF).

### General Notes

- Table is based on:
  - A load duration factor of 1.60 for combined lateral and vertical load.
  - A load duration factor of 1.00 for vertical load only.
  - Uniform lateral (wind) and vertical loads (beam weight considered).
  - Vertical deflection, the more restrictive of L/240 or ¼".
  - A maximum lateral (wind) load of 500 plf.

### Bearing Requirements

- Trimmers must support the full width of the header.
- Minimum header support to be one trimmer (1½") at ends.

### Maximum Allowable Vertical Load (PLF) with One Trimmer

Rough Opening	Wall Thickness	
	3½"	5½"
12'	355	536
10'	428	646
9'	476	718
8'	536	808
7'	613	924
6'	716	1,077
5'	858	1,290
4'	1,069	1,607
3'	1,415	2,126

# HEADER EXAMPLE

## Header Example

The **Design Example** on page 5 assumes that both headers will be the same size, and considers worst-case loading. Design the headers for lateral wind pressure of 23.6 psf based on the lower header's 6' rough opening and 10' tributary width, and a vertical load based on the upper header's maximum 250 plf.

- **Calculate the lateral load in plf:**

The calculated wind pressure in the example is 23.6 psf, so  $23.6 \times 10'$  tributary width = 236 plf.

- **Select the appropriate header:**

Scan the L/180 section of the **Header Load Table** to find a header that meets your requirements (236 plf lateral and 250 plf vertical). For this example, a 6' header of 5¼" x 5¼" 1.8E Parallam® PSL (at 500/955) will work for a 2x6 wall. Alternatively, a 7¼" x 3½" 1.3E TimberStrand® LSL header (at 500/290), used in plank orientation, will work for a 2x8 wall. Since the table numbers for these selections are not bold, only one trimmer stud is required for bearing. Headers that do not match the wall thickness must be directly attached to a plate that matches the wall thickness to provide lateral bracing. See detail L13 on page 12.

- **Design header to column connections:**

Convert 236 plf into a reaction (uniform load x length/2):  $236 (6'/2) = 708$  lbs. Use the **Lateral Connections** tables on page 13 to select a connection that meets or exceeds 708 lbs. For this example  $708/515 = 1.37$ ; so according to the **Angle Clips** connections table on page 13, two Simpson Strong-Tie® A34 connectors are sufficient—one on top and bottom at each end of both headers.

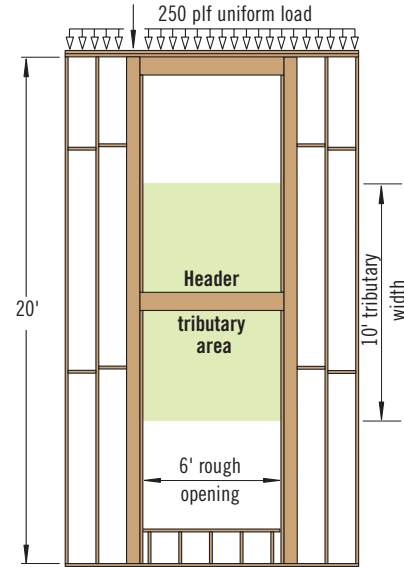

## MULTIPLE-MEMBER CONNECTIONS

### 2-Ply Nailing Recommendations

- **For 2x4, 1¾" x 5½", 2x6, 1¾" x 7¼", and 2x8:** Minimum of **two rows** of 16d (0.131" x 3¼") pneumatic nails at 10" on-center, staggered.
- Nail from one side.

### 3-Ply Nailing Recommendations

- **For 2x4:** Minimum of **two rows** of 16d (0.131" x 3¼") pneumatic nails at 8" on-center, staggered.
- **For 1¾" x 5½", 2x6, 1¾" x 7¼", and 2x8:** Minimum of **three rows** of 16d (0.131" x 3¼") pneumatic nails at 5" on-center, staggered.
- Nail from both sides.



### 4-Ply Fastening Recommendations

- **For 2x4:** Nail each ply to the other with a minimum of **two rows** of 16d (0.131" x 3¼") pneumatic nails at 5" on-center. When connecting each ply, offset nail rows by 2" from the ply below.
- **For 1¾" x 5½", 2x6, 1¾" x 7¼", and 2x8:**
  - Nail each ply to the other with a minimum of **three rows** of 16d (0.131" x 3¼") pneumatic nails at 5" on-center. When connecting each ply, offset nail rows by 2" from the ply below.
  - or,
  - Minimum of **two rows** of ½" diameter bolts spaced at 8" on-center.

## PRODUCT STORAGE



Protect product from sun and water

**CAUTION:**  
Wrap is slippery when wet or icy

Align stickers (2x3 or larger) directly over support blocks

Use support blocks (6x6 or larger) at 10' on-center to keep bundles out of mud and water

# TYPICAL TALL WALL FRAMING

## WARNING

Safety bracing during construction is required for lateral stability. Lack of proper bracing or insufficient wall system design can result in serious accidents.

Wall reinforcement is required at all lift points to ensure wall stability during construction

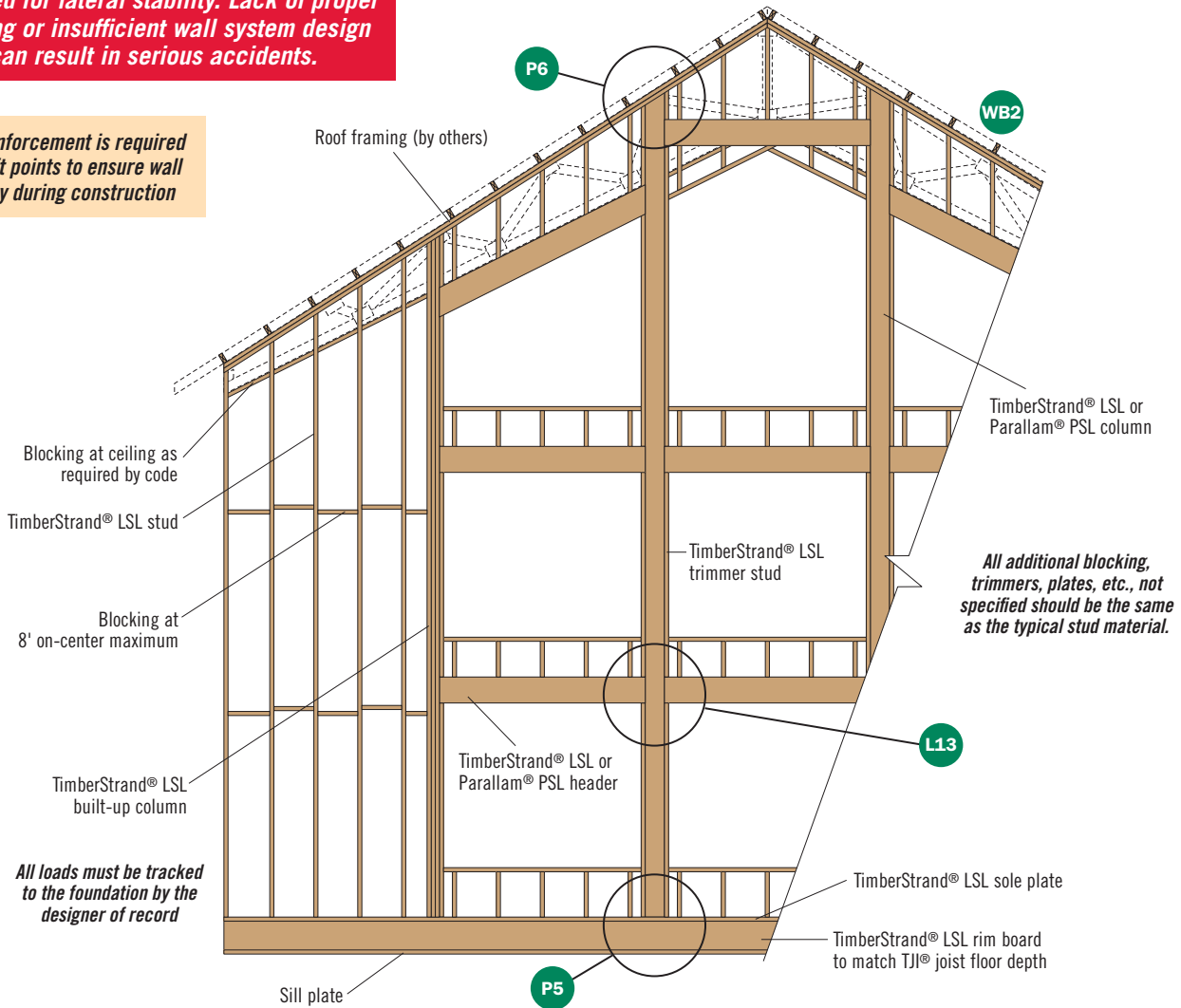

## WALL DETAILS

### Header to Column

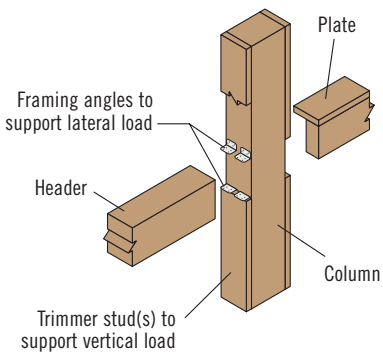

**L13** Plate width must equal the wall thickness to provide lateral bracing. (Plate not required if header width equals the wall thickness.)

### Column or Stud to Bottom Plate

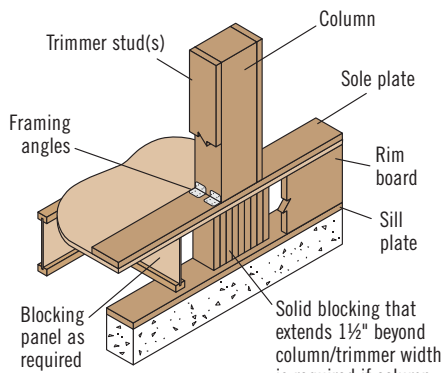

**P5** Solid blocking that extends 1 1/2" beyond column/trimmer width is required if column and trimmer studs do not extend to sill plate

### Column or Stud to Top Plate

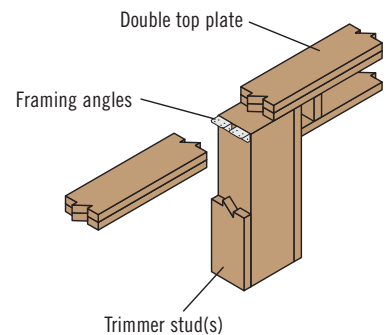

**P6**

# WALL DETAILS

## Wind Brace

Details shown are applicable for 90 mph (2009 IRC/IBC) or 115 mph (2012 and 2015 IRC/IBC) basic wind speeds and the exposure categories and maximum wall heights shown in the table below. For other conditions, contact your Weyerhaeuser representative.

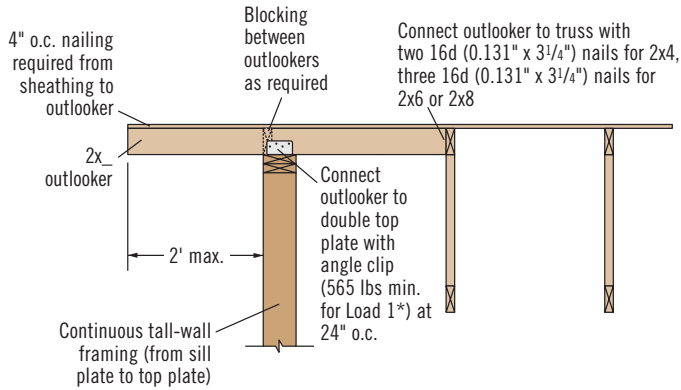

**WB2** \* Load 1 value from Lateral Connections—Angle Clips table below.

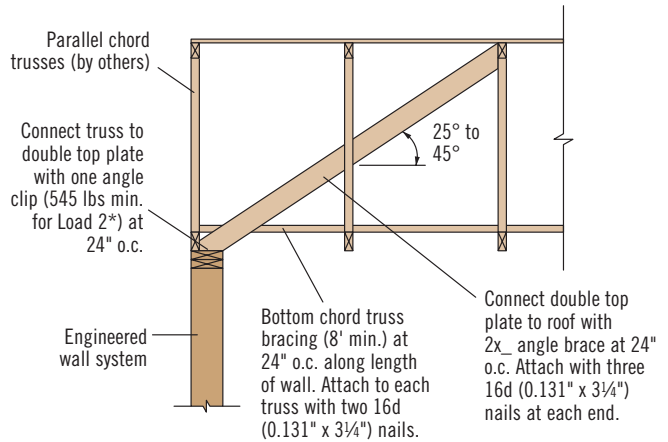

**WB3** \* Load 2 value from Lateral Connections—Angle Clips table below.

## Wind Brace Detail Applicability

Detail	Exposure	Max. Wall Height
WB2	D	25'
	B, C	29'
WB3	B, C	20' <sup>(1)</sup>

(1) Maximum wall height shown includes depth of truss.

## FRAMING CONNECTORS

### Lateral Connections—Nails

Nail Size	End Grain	Toe Nail
8d (0.113" x 2½")	77 lbs	96 lbs
10d (0.128" x 3")	99 lbs	123 lbs
12d (0.128" x 3¼")	99 lbs	123 lbs
16d (0.135" x 3½")	110 lbs	137 lbs
16d (0.131" x 3¼")	104 lbs	129 lbs

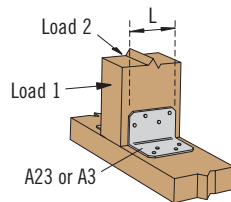

### General Notes

- Tables are based on a load duration factor of 1.60.
- Connection values based on a specific gravity of 0.50.
- For end-grain connections, a 0.67 factor was used (based on NDS®).
- For toenail connections, a 0.83 factor was used (based on NDS®).

### Lateral Connections—Angle Clips

Type	Nails	Length of Connector (L)	Load 1: Allowable Load (lbs)	Load 2: Allowable Load (lbs)
<b>Simpson Strong-Tie®</b>				
A21	Four 10d (0.148" x 1½")	1¾"	175	365
A34	Eight 8d (0.131" x 1½")	2½"	515	455
A35	Twelve 8d (0.131" x 1½")	4½"	695	670
A23	Eight 10d (0.148" x 1½")	2¾"	565	715
<b>USP Structural Connectors®</b>				
AC5	Six 10d (0.148" x 1½")	4¾"	540	540
A3	Eight 10d (0.148" x 1½")	2¾"	590	600
AC7	Eight 10d (0.148" x 1½")	6 <sup>15</sup> / <sub>16</sub> "	725	725
AC9	Ten 10d (0.148" x 1½")	8¾"	905	905

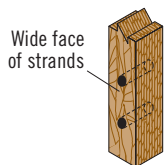

In order to use the manufacturer's published capacities when designing column caps, bases, or holdowns for uplift, the bolts or screws must be installed perpendicular to the wide face of strands as shown at left.



DO NOT install bolts or screws into the narrow face of strands

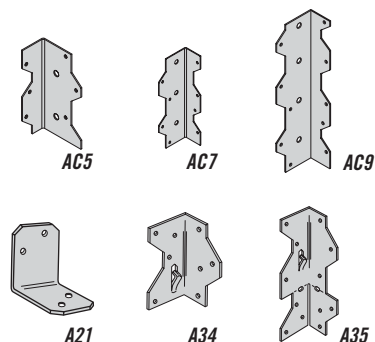

# ALLOWABLE HOLES

## 1.55E TimberStrand® LSL Headers and Beams

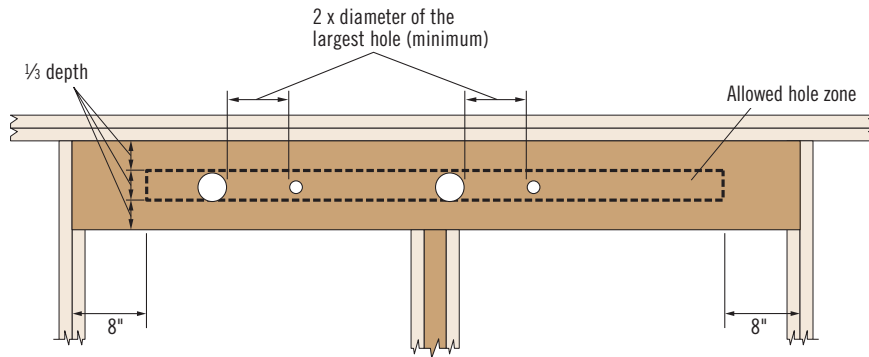

### General Notes

- Allowed hole zone suitable for headers and beams with **uniform and/or concentrated loads** anywhere along the member.
- Round holes only.
- No holes in headers or beams in plank orientation.

### 1.55E TimberStrand® LSL

Header or Beam Depth	Maximum Round Hole Size
9¼"–9½"	3"
11¼"–11⅞"	3⅝"
14"–16"	4⅝"

- See illustration for allowed hole zone.

## Other Trus Joist® Headers and Beams

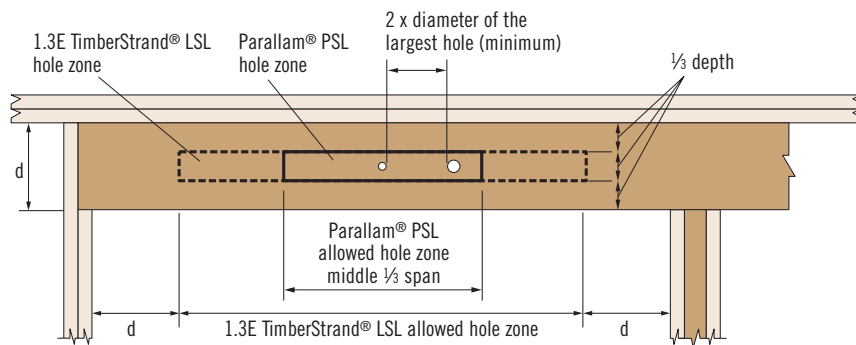

### General Notes

- Allowed hole zone suitable for headers and beams with **uniform loads only**.
- Round holes only.
- No holes in cantilevers.
- No holes in headers or beams in plank orientation.

### Other Trus Joist® Beams

Header or Beam Depth	Maximum Round Hole Size
4⅞"	1"
5½"	1¾"
7¼"–20"	2"

- See illustration for allowed hole zone.

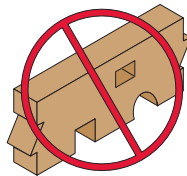

**DO NOT cut, notch, or drill holes in headers or beams except as indicated in the illustrations and tables above**

## Allowable Holes and Notches\* for TimberStrand® LSL Studs

Per ICC ESR-1387, holes may be drilled anywhere along the length of the stud but must be at least ⅜" from the edge

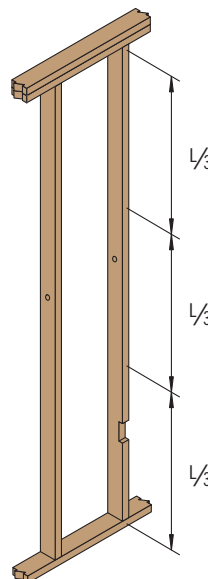
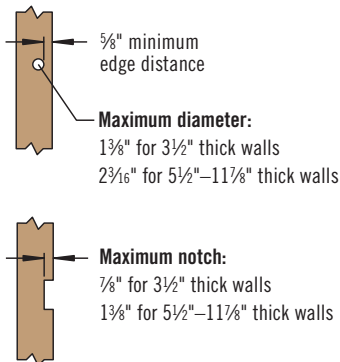

**One notch may be cut anywhere except the middle ⅓ of the length of the stud**



**DO NOT cut a notch and a hole in the same cross section**

\* Applies to stud applications other than 2x4 and 2x6 studs in conventional construction as shown on page 3.

# DESIGN PROPERTIES

## Allowable Design Stresses (100% Load Duration)

Grade MOE (x10 <sup>6</sup> ) (psi)	E <sub>min</sub> <sup>(1)</sup> (psi)	Axial		Joist/Beam			Plank			Equivalent Specific Gravity for Connections		
		F <sub>c  </sub> (psi)	F <sub>t</sub> <sup>(2)</sup> (psi)	F <sub>b</sub> <sup>(3)</sup> (psi)	F <sub>v</sub> (psi)	F <sub>c⊥</sub> <sup>(4)</sup> (psi)	F <sub>b</sub> (psi)	F <sub>v</sub> (psi)	F <sub>c⊥</sub> <sup>(4)</sup> (psi)	Shear Walls <sup>(5)</sup>	Lateral	Withdrawal
<b>TimberStrand® LSL</b>												
1.3	660,750	1,835	1,075	1,700 <sup>(6)</sup>	425	710	1,900	150	635 <sup>(11)</sup>	0.42 <sup>(7)</sup>	0.50	0.42
1.5	762,400	2,105	1,500	2,250 <sup>(6)</sup>	505	860	2,525	150	750	0.42		
1.55	787,815	2,170	1,070 <sup>(8)</sup>	2,325 <sup>(6)</sup>	310 <sup>(8)</sup>	900	2,615	150	775	0.42		
<b>Parallam® PSL</b>												
1.8	914,880	2,500	1,755	2,500 <sup>(9)</sup>	230	545	2,400 <sup>(9)</sup>	190	545	N.A.	0.50	0.50
2.0	1,016,535	2,900 <sup>(10)</sup>	2,025	2,900 <sup>(9)</sup>	290	625	2,650 <sup>(9)</sup>	210	635			

(1) Reference modulus of elasticity for beam and column stability calculations per NDS®.

(2) F<sub>t</sub> has been adjusted to reflect the volume effects for most standard applications.

(3) When structural members qualify as repetitive members in accordance with the applicable building code, a 4% increase is permitted for F<sub>b</sub> in addition to the increases permitted in Footnotes 6 and 9.

(4) F<sub>c⊥</sub> may not be increased for duration of load.

(5) Design shear wall applications per 2009 IBC Table 2306.3 or AWC SDPWS. When using StrandGuard® TimberStrand® LSL sill plate, see the *Trus Joist® Treated Sill Plates, Columns, and Studs Technical Brief*, TJ-8100.

(6) For 12" depth. For depths < 3½", use the 3½" factor; for other depths, multiply by  $[\frac{12}{d}]^{0.092}$ .

(7) Do not use 2009 IBC Table 2306.3 or AWC SDPWS with nail spacings less than 6" on-center. (Studs at boundary locations, where two panels abut, are allowed two rows at 6" on-center.)

(8) Value accounts for large hole capabilities. See **Allowable Holes** on page 14.

(9) For 12" depth. For depths < 3½", use the 3½" factor; for other depths, multiply by  $[\frac{12}{d}]^{0.111}$ .

(10) For column and stud applications, use F<sub>c||</sub> of 500 psi. Alternatively, refer to ESR-1387, Table 1, footnote 15.

(11) For 1½" thick members, use F<sub>c⊥</sub> of 670 psi in plank orientation.

## Allowable Design Properties (100% Load Duration)

### 1½" TimberStrand® LSL Studs

Design Property	Beam Orientation		
	1.3E		
	3½"	5½"	7¼"
Moment (ft-lbs)	485	1,150	2,580
Shear (lbs)	1,490	2,340	3,660
Moment of Inertia (in. <sup>4</sup> )	5	21	48
Weight (plf)	1.5	2.4	3.3

### 1¾" TimberStrand® LSL Studs

Design Property	Beam Orientation	
	1.55E	
	5½"	7¼"
Moment (ft-lbs)	1,835	3,110
Shear (lbs)	1,990	2,620
Moment of Inertia (in. <sup>4</sup> )	24	56
Weight (plf)	3	4.0

### Beam Orientation

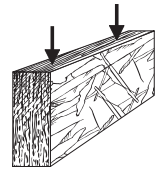

### 3½" TimberStrand® LSL Columns and Headers

Design Property	1.3E					1.55E			
	Beam Orientation			Plank Orientation		Beam Orientation			
	5½"	7¼"	8⅝"	5½"	7¼"	5½"	7¼"	9½"	11⅞"
Moment (ft-lbs)	2,685	4,550	6,335	1,780	2,345	3,675	6,225	10,420	15,955
Shear (lbs)	5,455	7,190	8,555	1,925	2,540	3,980	5,245	6,870	8,590
Moment of Inertia (in. <sup>4</sup> )	49	111	187	20	26	49	111	250	488
Weight (plf)	5.6	7.4	8.8	5.6	7.4	6	7.9	10.4	13.0

### Column Orientation



### 3½" Parallam® PSL Columns

Design Property	1.8E					2.0E
	Beam Orientation			Plank Orientation		Beam Orientation
	3½"	5¼"	7"	5¼"	7"	9¼"
Moment (ft-lbs)	1,640	3,670	6,320	2,460	3,275	12,415
Shear (lbs)	1,550	2,820	3,755	2,330	3,105	6,260
Moment of Inertia (in. <sup>4</sup> )	13	42	100	19	25	231
Weight (plf)	3.8	5.7	7.7	5.7	7.7	10.1

### Plank Orientation

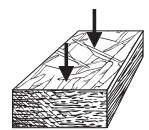

### 5¼" Parallam® PSL Columns and Headers

Design Property	1.8E			2.0E	
	Beam Orientation		Plank Orientation	Beam Orientation	Plank Orientation
	5¼"	7"	7"	9¼"	9¼"
Moment (ft-lbs)	5,285	9,485	7,050	18,625	10,285
Shear (lbs)	3,490	5,635	4,655	9,390	6,800
Moment of Inertia (in. <sup>4</sup> )	63	150	84	346	112
Weight (plf)	8.6	11.5	11.5	15.2	15.2

### 7" Parallam® PSL Columns

Design Property	1.8E	2.0E
	Beam Orientation	Plank Orientation
	7"	9¼"
Moment (ft-lbs)	12,140	17,710
Shear (lbs)	6,205	9,065
Moment of Inertia (in. <sup>4</sup> )	200	264
Weight (plf)	15.3	20.2

## WE CAN HELP YOU BUILD SMARTER

You want to build solid and durable structures—we want to help. Weyerhaeuser provides high-quality building products and unparalleled technical and field assistance to support you and your project from start to finish.

**Floors and Roofs:** Start with the best framing components in the industry: our Trus Joist® TJI® joists; TimberStrand® LSL rim board; and TimberStrand® LSL, Microllam® LVL, and Parallam® PSL headers and beams. Pull them all together with our self-gapping and self-draining Weyerhaeuser Edge Gold™ floor panels and durable Weyerhaeuser roof sheathing.

**Walls:** Get the best value out of your framing package—use TimberStrand® LSL studs for tall walls, kitchens, and bathrooms, and our traditional, solid-sawn lumber everywhere else. Cut down installation time by using TimberStrand® LSL headers for doors and windows, and Weyerhaeuser wall sheathing with its handy two-way nail lines.

**Software Solutions:** Whether you are a design professional or lumber dealer, Weyerhaeuser offers an array of software packages to help you specify individual framing members, create cut lists, manage inventories—even help you design a complete structural frame. Contact your Weyerhaeuser representative to find out how to get the software you need.

**Technical Support:** Need technical help? Weyerhaeuser has one of the largest networks of engineers and sales representatives in the business. Call us for help, and a skilled member from our team of experts will answer your questions and work with you to develop solutions that meet all your structural framing needs.



### LIMITED LIFETIME PRODUCT WARRANTY

Weyerhaeuser provides a limited warranty for the expected life of the structure for all Trus Joist® branded products. Product information, installation instructions, and the full text of each product's limited warranty (including limitations and exclusions) are available on the Weyerhaeuser website, from your Weyerhaeuser representative, or by calling toll free: 888-453-8358.

Additionally, Weyerhaeuser offers limited warranties on a broad variety of its other products. To see complete details of all Weyerhaeuser product warranties, visit [weyerhaeuser.com/woodproducts/warranty](http://weyerhaeuser.com/woodproducts/warranty).

1.888.453.8358
[WEYERHAEUSER.COM/WOODPRODUCTS](http://WEYERHAEUSER.COM/WOODPRODUCTS)

Revised 11/2016 December 2016. Weyerhaeuser and Trus Joist are registered trademarks of Weyerhaeuser LLC. © 2016 Weyerhaeuser NR Company. All rights reserved.

### CONTACT US

1.888.453.8358 • [weyerhaeuser.com/woodproducts/contact](http://weyerhaeuser.com/woodproducts/contact)

Contact your local representative or dealer at:

Visit [weyerhaeuser.com/woodproducts/warranty](http://weyerhaeuser.com/woodproducts/warranty) for copies of this and other Trus Joist® Engineered Wood Product warranties.

June 2017 • Reorder TJ-9003

This document supersedes all previous versions. If this is more than one year old, contact your dealer or Weyerhaeuser rep.

Weyerhaeuser, Forte, Microllam, Parallam, TimberStrand, and Trus Joist are registered trademarks and Edge Gold is a trademark of Weyerhaeuser NR. © 2017 Weyerhaeuser NR Company. All rights reserved. Printed in the USA.